

NATIONAL AUTOGRASS SPORT ASSOCIATION LTD



SCRUTINEERS COMMITTEE MEETING

REF: S4MIN1019/VM/GIJ

SUNDAY, 12th OCTOBER 2019 - 11.00 am

METRO INN, Birmingham Road, Walsall WS5 3AB.

C. SCRUTINEERS	No.	LEAGUE	SCRUTINEERS CLUB
Y	16	CGTRO(LINCOLN)	EA
Y	14	EAST ANGLIA	Rad
Y	01	EAST MIDLANDS	EA
*	11	ESSEX	S
*	24	FENLAND	EML
Y	02	GLOUCESTER	MAP
Y	23	IRELAND	
*	18	KENT	
Y	07	MIDLAND AP	
Y	09	NORTH WESTERN	
*	21	NORTHERN IRELAND	
Y	10	NORTH YORKSHIRE	
*	25	SCOTTISH	
*	15	SHROPSHIRE AA	
Y+	05	SOUTHERN	
*	04	SOUTH WALES	
*	19	THE DALES	
Y	06	WEST MIDLANDS	
Y	22	WILTSHIRE	
Y+	12	YORKSHIRE	

NASA Director VM – Scrutineering.
NASA Scrutineer AT.
NASA Scrutineer DG.
NASA Scrutineers Secretary.

APOLOGIES:

Scrutineers marked + are Club scrutineers representing League in place of League Chief Scrutineer.

VISITORS:

**ASSOCIATION OF
AUTHORISING
BODIES**

Office: 46 Brookside, Alconbury, Huntingdonshire PE28 4EP
Registered in England and Wales – Company No. 1716574

1. INTRODUCTION

NASA Director VM welcomed all and thanked all for attending.

The Scrut. Sec. handed out agenda, previous meeting minutes and voting cards.

2. MINUTES OF PREVIOUS MEETING 08/06/19 and MATTERS ARISING:

Page 3. – Pre-Season Scrutineering.

NASA Director VM commented that this was likely to become mandatory soon. The matter is on the agenda for the chairmen's meeting today – See later in meeting.

Page 3. Blue/Red Tagging

The CGTRO rep. enquired of situation regarding Red Tag.

NASA Director VM commented that there had been difficulties in keeping the Blue tag information up to date. Competitors were not always cooperative. They often do not follow the correct procedure and provide information so that NASA's records can be maintained as accurate. Cars are being sold on etc; without either the old or new owner informing NASA.

In vie of this the Red Tag introduction is being delayed.

However if any specific League wishes to carry out pre-season scrutineering and also issue and monitor Red Tags for their vehicles then NASA may sanction this and issue the league with Red Tags. The League would then update NASA.

Brief discussion followed with reference to. Tagging procedure. Difference between vehicles of those competitors that "Travel" and those that only race within their own Club or League. Use of Red Tag will lessen scrutineering time for travelling competitors. They may still be subject to spot checks and safety checks.

Page 3. Junior Age Limit reduction.

NASA Director VM commented that the requirements had been agreed and they were due to be sent to insurers for comment.

All new Juniors in 2020, will have to be subject to a scrutineering safety check prior to race day and also prior to racing. This will minimise disappointment if a Junior and supporting family turns up on race day and due to failing the initial safety check not being permitted to race.

The prior to race day safety check at a nominated venue will concern – seat position and location, reaching of pedals, controls, steering and isolation switch, harness fitment and also a driven track test.

It was suggested that the new juniors should have to wear gloves. There also may be a requirement to have a novice sticker on vehicle until the Junior's 12th birthday.

Page 4. National Championships – Scrutineering.

NASA Director VM commented that at the Men's scrutineering procedure had changed for this year, but had not been as successful as hoped. – See later in meeting.

Page 5. Toyota Yaris - Towing Eye.

NASA Director VM commented that since previous meeting concerns had been expressed regarding the size of the towing eye.

Brief discussion followed including reference to its size and use of a flexible towing eye in its place. Some scrutineers have required its removal already. The original steel towing eye must be removed; however the threaded boss must be retained.

It was agreed that the rules be amended to suit.

Page 5. Weight of Vehicles.

NASA Director VM commented that since previous meeting no feedback had been received. Feedback is required.

Page . 6. Class 6 – Location of suspension/engine/radiator cradle

The CGTRO rep. still strongly disagreed with the changes for 2019, as the original pre-2019 rules were sufficient why and by whom were they changed? There are many vehicles that complied with the previous 2015/6 rules but not the 2019 rule. He was working to the previous rules.

Scrut. Sec. commented that the rule 2.7iii applied to space frame vehicles. If the original front chassis and say mini sub-frame etc were retained then the 2.7iii rule did not apply.

Brief discussion followed including reference to. Specific rule 2.7iii. Previous Rule. No non compliant vehicle identified. Issue been discussed previously.

NASA Director VM commented that the rule concerned had been changed during the discussions held for the formation of the 2019 rules. However if those present agreed then the wording of the previous rule could be incorporated to, as stated in previous meeting clarify, the situation.

It was agreed that this be carried out.

Page . 6. Junior Specials – Alternative engines.

NASA Director VM commented that Mr GB had been investigating this, the aim being to find an alternative engine ready for when the current Vauxhall engine becomes hard to find. Any alternative engine must be such that the present cars and engines are still competitive. Feedback was still required from Leagues regarding this.

No other matters arising.

PROPOSED: CGTRO Rep.

SECONDED: EA Rep.

That the minutes be accepted as a true record.

UNANIMOUS -

CARRIED

3. CORRESPONDENCE.

Email from Mr KH – See later discussion.

No other correspondence.

4. JANUARY 2019 EDITION NASA VEHICLE CONSTRUCTION RULES AND REGULATIONS:

a. Class 1 & 2. Experimental vehicles / Trials.

The NW C1 had the cage and body corrected and had just been Blue tagged and given number NASA97. It was doing the winter series races.

The York C1 was only racing in League. It seems underpowered but handles ok.

The KIA Picanto is to have its shock absorbers changed.

The Class 2 Micra had changed shock absorbers, but was underpowered with standard gearbox. The fitting of a 1.0 gearbox had improved performance.

Brief discussion including reference to non standard gearbox. 1.3 box should be retained. This needs considering if car permitted and rules created. Mr KB in process of drafting some specific Class 2 – Micra rules.

b. Tyres.

NASA Director VM informed the meeting of the current situation.

The new 2019 rules now apply to all NASA race meetings. Things have settled down and the rules have been accepted and complied with by nearly all.

2 persons have been subject to disciplinary action for non-compliance. 1 person at a BAS round, the other at a UKAC round. They original were given a 1 year ban, subsequently reduced to 6 months. In future a mandatory 1 year ban will be in place.

Another tyre supplier has expressed an interest in providing tyres. He is awaiting details.

A tyre meeting is due soon.

Brief discussion followed including reference to. Carrying out of tyre testing – done on a random basis all ok. In general terms the 2019 specification tyres seemingly have little effect on performance compared to previous tyres.

c. Scrutineering Report.

Class 4.

NASA Director VM commented that the class had changed little so far, he invited comments.

Brief discussion followed including reference to. Some cars are racing to new rules. Increase in capacity for minis helpful. Imp vehicle more competitive due to permitted gearbox change. Cost still an issue. Replace class with stock hatch. Allow Peugeot engine an increase in capacity. Further rule changes may be required for 2021.

NASA Director VM requested that leagues discuss this further and provide feedback.

Traction Control / GPS

NASA Director VM expressed concern regarding the alleged use of these systems. More investigation is needed as to the applications available and potential advantages of their use. Technology is moving on.

Discussion followed including reference to. Data logging. Use of systems to aid traction control. Start line and or race settings - presets of rev limits for different track conditions – wet/dry etc. 2 stage rev limiter use. Electronic rather than driver control of throttle. Push button hand or foot or pedal operation. Start line electronic aids should be prohibited – already are as traction control prohibition.

NASA Director VM invited an indicative vote to aid future consideration.

Prohibition of 2 stage rev limiters – **VOTE: FOR = 11 AGAINST = 0 ABSTENTION = 1.**

2019 National Championships - General

NASA Director VM thanked those that attended and helped for their efforts.

The condition of vehicles in general was good. There were several minor non-compliance issues. Some required attention immediately – 6mm seat bolts in place of 10mm. Others were written in licences.

Some new methods had been tried at Men’s and not all had been successful. Ladies & Junior was better.

Email from Mr KH.

NASA Director VM explained that the Directors had received an email. He read out contents.

Précis of email.

Scrutineering took too long, in some instances 6 -7 hours and was stressful for drivers. Suggestion that all vehicles are pre-season scrutineered. Those that qualify subject to thorough pre Nationals check up to 2 weeks before by local League Chief scrutineer at specified venue. If certain leagues not confident, then shared with neighbouring league or Board send assistance. Scrutineers paid for time (@ previously agreed cost and split between drivers and league.). Acknowledge the need for pre-race checking. Classes given time slot to attend check lanes. (e.g. Class 1 12 – 12.30, Class 2 12.30 – 3.00 etc. Problem cars to be removed and checked later.

NASA Director VM commented that a reply had been give stating that it would be discussed at this meeting. Many of the points raised had been considered previously. However a way forward was to make pre-season scrutineering mandatory. This is on the agenda for the Chairmen’s meeting and it was up to them.

NASA Director VM commented that pre-season checking would help to raise the standard and ensure less conflicts when competitors travelled to out of league race meetings. He invited comments.

The CGTRO rep. objected to it being made mandatory. Others were broadly supportive.

2019 National Championships – Mens Report.

During racing one vehicle found to be non-compliant, following heat spot checks, and disqualified.

Class – 1

Car No.	Driver	Item
IK888	MH	Non compliant temperature indication. Rule 1.8.

There were no other scrutineering issues during racing.

Scrutineering – Post Race “Men’s”

Usual check carried out. Camshafts were retained for checking – all OK and returned.

3 vehicles found non-compliant.

Class – 1

Car No.	Driver	Item
SV101	CG	Non compliant balancing of engine components. Rule 1.5iii.
SS20	AM	Non compliant balancing of engine components. Rule 1.5iii.

Class – 2

Car No.	Driver	Item
P56EM	DH	Non compliant Piston “proud” more than permitted of engine block top face. Rule 20 – Check Sheet.

All other vehicles checked were found to comply with the relevant class cc limits and engine preparation regulations.

Class 1 Race Results now confirmed as: 1st Y121, 2nd E100, 3rd NS443, 4th WS20, 5th NW44, NF SR174.

Class 2 Race Results now confirmed as: 1st SC1, 2nd YD203, 3rd SN34, 4th YD104, 5th E219, NS LUD15.

2019 National Championships – Ladies & Junior Report.

NASA Director VM thanks those that attended and helped for their efforts.

The pre-race scrutineering had been thorough but fair and had uncovered faults. Some of the faults should have been picked up at their local club/league checks.

Fewer scrutineers attended.

Junior Specials offered opportunity to get weighed. Most had been weighed. 3 found underweight initially before racing. All had been informed that they will be re-checked over weekend.

During racing 2 vehicles found to be non-compliant, following heat spot checks, and disqualified.

Class – 1

Car No.	Driver	Item
WW193	EL	Exhaust valve lift exceeded maximum permitted. Rule 20 – Check sheet.

Class – Jnr Specials.

Car No.	Driver	Item
NW39	GB	Vehicle weight below permitted minimum. Rule 8.2.

There were no other scrutineering issues during racing.

Scrutineering – Post Race ‘Ladies & Junior.

Usual check carried out. Camshafts were retained for checking – those OK were returned.
3 vehicles found non-compliant.

Class – 1 Jnr

Car No.	Driver	Item
B16H	TC	Non compliant suspension components. Rule 17.1. Use of cut down front cones as spacers.

Class 1 Jnr. Race Results confirmed as: 1st SC24, 2nd CA42, 3rd S11Y, 4th MA182, 5th NW52, 6th H90, 7th WS90.

Class – 2

Car No.	Driver	Item
WW358	JH	Non compliant valve seats – Rule 1.6.
SL212	LH	Non compliant valve seats – Rule 1.6.

Class 2 Race Results confirmed as: 1st R3, 2nd SV51, 3rd IK13, 4th E101, BF SC1, NF YD203.

All other vehicles checked were found to comply with the relevant class cc limits and engine preparation regulations.

For a post race disqualification the driver’s licence number was noted together with the vehicles tag number.
Disciplinary punishment issued to driver and car.

Future National Championship Scrutineering.

NASA Director VM indicated that there may be changes to post race scrutineering procedures and requirements in future.

A larger scrutineering tent complete with “bay separation” to allow more control and privacy.

Employment of security personnel to assist in person’s behaviour control.

e. Rules Clarification requests from League Scrutineers

Class 1 – Micra – Brake Discs.

The Ireland rep. expressed concern that genuine replacement brake discs are dimensionally below the measurements stated in the Micra Check Sheet. Local competitors have obtained several from different suppliers and all are smaller in diameter by approx 1mm. Can the check sheet be amended to suit.

NASA Director VM indicated that if information is supplied to confirm this than the figures may be amended, subject to rules discussions.

Mr Warren agreed to forward the relevant information soon.

Class 1 – Micra – Replacement Shock Absorbers..

The Ireland rep. enquired if "Bilstein" B4 monoshock can be added to the list of permitted replacement shock absorbers. They are approx £60 each, comparative to existing permitted units.

NASA Director VM indicated that if information is supplied to confirm this than the figures may be amended, subject to rules discussions.

Class 1 – Micra – Coil Pack engine Pistons.

NASA Scr. AT reminded all that the pistons as fitted to the later "Coil Pack" engines are not permitted for use in non-coil pack engines. These pistons can be identified by the piston rings being in a different location to the non coil pack engines. The mixing and matching of components is not permitted.

Class 7 – Front engine.

The MAP rep. enquired if a front engine RWD vehicle is allowed in class 7. – YES.

Scrut. Sec. commented that the rules were originally amended to suit a competitor who had constructed a motorbike engined (in-line) class 3 car. The vehicle had not been permitted into class 3 at the time and had had to race in class 7. Front engined RWD pick up vehicles are also permitted.

Handbrake.

The MAP rep. enquired if the handbrake rules are still relevant. They state that the handbrake must operate the rear wheels only; however this is not being enforced as other wheel brakes may have handbrake operation in addition to foot brake. Also electric handbrake is prohibited, but they are being used.

NASA Director VM invited comments.

Discussion followed including reference to. Push button hand or foot or pedal operated electric systems used as brake controls.

It was agreed that the relevant rule wording be amended to prohibit Electric/electronic handbrake/parking brake.

Class 6 – Radiator location

Can the front body/grille area be extended forwards to allow fitment of a front mounted radiator? – NO.

NASA Director VM confirmed that the front area cannot be extended forward.

The original shape and silhouette must be retained as required by rules.

5. JANUARY 2020 EDITION RULES & REGULATIONS

Rules for clarification. - None at present.

Rules for 2020.

Class 2

Use of wide wheels are to be restricted.

As of January 2020 the maximum permitted width will be 6J.

Rear Wheel Drive vehicles (RWD) to be phased out.

As of January 2020 only Front Wheel Drive (FWD) vehicles will be permitted.

Clarification amendments to rules:

Class 1 – Micra - Disc brake size may have a tolerance (subject to confirmatory information) introduced to ensure that correct Nissan and or aftermarket replacement items may be used, as discussed in meeting.

Class 1 – Yaris – Towing eye must be removed. The boss must be retained. Flexible towing eye permitted.

Class 2 – Yaris – Towing eye must be removed. The boss must be retained. Flexible towing eye permitted.

Class 4, 5, & 6. Front engine vehicles – Rule 2.7iii to be clarified as discussed in meeting.

All Classes

Saloons – Steel Towing eye must be removed. Flexible towing eye permitted.

Saloons - Electronic brake system prohibited. Rule 12.4 to be amended as discussed in meeting.

2 Stage rev limiter Prohibited.

Specials - Electronic brake system prohibited. Rule 12.4 to be amended as discussed in meeting.

2 Stage rev limiter Prohibited.

6. A.O.B.

Hans Device & Harness.

The Wiltshire rep. expressed concern that some competitors were using the "Hans Device" with incorrect size harness. Also the condition and fitment of some harnesses at the Ladies & Junior Championships were poor.

NASA Director VM reminded all that these devices must be used with correct sized harness and correct fixings. Also all harnesses must be in good condition and a good fit to the competitor at all times.

Post Championship Checking – UKAC

NASA Director VM commented that 2 vehicles had refused to comply with attendance at post championship scrutineering. Both competitors concerned have been asked again and given a deadline for response.

Vehicle a. - Class 1. The car had been sold but allegedly the new owner has indicated that it needs to be checked.

Vehicle b. - Class 2. Awaiting response.

Junior Specials – Pedal Box – Small Stature 10 year old.

Can the pedal box be moved to suit the person's small stature?

NASA Director VM confirmed that the pedal box may be moved rearwards to suit the stature and to enable the vehicle to be correctly controlled.

No other items.

MEETING CLOSED 1.10 pm.

“Official” scrutineer’s jackets

Very few **“orange” “official” scrutineers’ jackets** have been returned to Scrutineers Sec. following the National Championships. Could they please be returned as soon as possible?

These jackets are intended for use at the National Championship Meetings only.

1. Scrutineers must give all assistance required to drivers/constructors in preparing vehicles to comply with the 2019/20 Edition Rule Book.
2. For future reference: **WANTED:**
Details, photographs, etc. of reasons for vehicles to fail scrutineering, examples of incorrect or dangerous practices.
- 3 **FUTURE MEETINGS: 11.00 am. Metro Inn, Birmingham Rd, Walsall WS5 3AB**
Scrutineers Committee meetings: Provisional 2019 dates: /02/20, /04/20, /06/20, /10/20.
ALL DATES AND TIME TO BE CONFIRMED

NASA AGM 24 November 2019

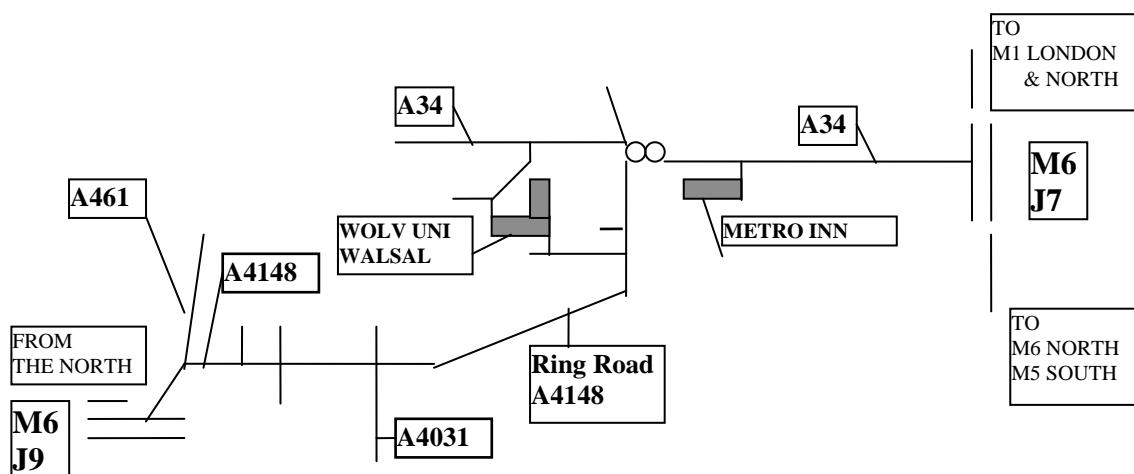

People attending the meeting must park their vehicles in CAR PARK. PLEASE DO NOT PARK ON THE GRASS.

Follow signs to RECEPTION, a porter will then direct you to the correct room.

You are advised to bring your own refreshments.

The Metro Inn has a NO-SMOKING rule.

4. Comments required from leagues on:
NASA Rules & Regulations - Clarification's, Changes for future etc.
- =====